

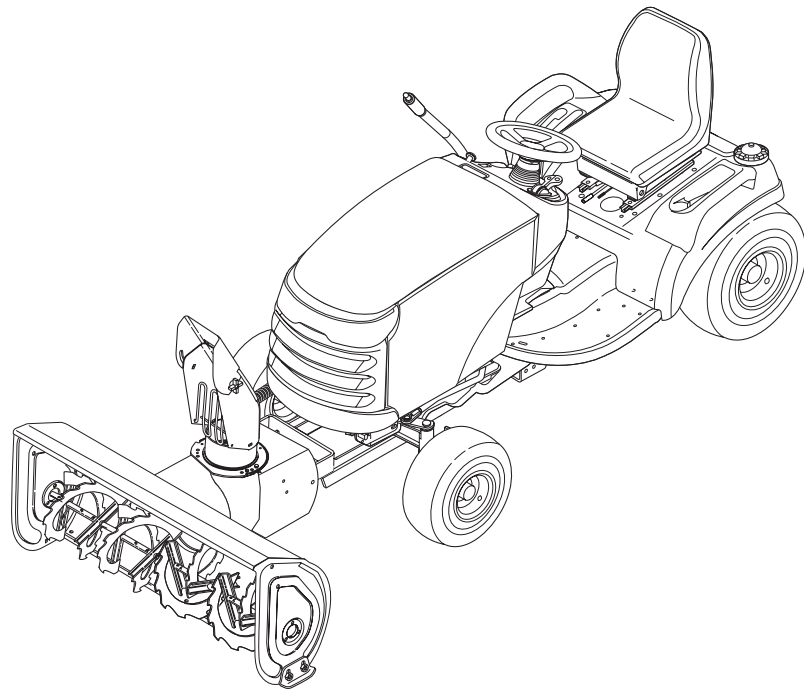

# ATTACHMENT OPERATOR'S MANUAL



## 42" Single-Stage Snowthrower

42" Snowthrower Attachment	
Mfg. No.	Description
1694920	42" Single-Stage Snowthrower

1733943  
Revision 01  
Rev. Date 9/2006  
TP 100-4388-01-AT-SMAN



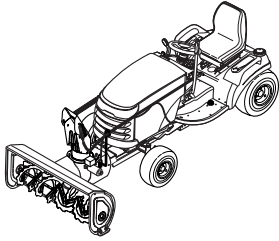

# Table of Contents

<b>Recommended Accessories .....</b>	<b>1</b>	<b>Maintenance</b>	
<b>Safety Rules &amp; Information</b>		Schedule for Normal Care .....	9
Training .....	2	General Lubrication .....	9
Preparation .....	2	<b>Troubleshooting, Adjustments &amp; Service</b>	
Operation .....	2	Troubleshooting Chart .....	10
Children .....	3	Skid Shoe Adjustment .....	11
Clearing a Clogged Discharge Chute .....	3	Electric Chute Rotator Gear .....	11
Service, Maintenance and Storage .....	3	Lift Adjustment .....	12
Emissions .....	3	Belt Tension Adjustment .....	12
Decals .....	4	Belt Replacement .....	13
<b>Required Accessories .....</b>	<b>5</b>	<b>Initial Setup &amp; Assembly</b>	
<b>Recommended Accessories .....</b>	<b>5</b>	Snowthrower Components .....	14
<b>Clean-Out Warning and Procedure .....</b>	<b>5</b>	Chute Assembly .....	15
<b>Features &amp; Controls</b>		Install Hitch onto Tractor .....	16
Control Functions .....	6	Attaching Blower to Tractor .....	17
<b>General Operating Instructions</b>		Attaching Lift Arm Assembly to Tractor .....	18
Checks Before Starting .....	7	Attaching Chute Motor Wiring Harness .....	19
Engine & Ground Speed Selection .....	7	Install Reflectors .....	19
Stopping & Starting .....	7	<b>Removal</b>	
Transporting .....	7	Snow Thrower Removal .....	20
Snow Removal Suggestions .....	8		
Daily Storage .....	8		
Off-Season Storage .....	8		

*NOTE: In these instructions, "left" and "right" are referred to as seen from the operating position.*

# Safety Rules & Information



This machine is capable to amputating hands and feet and throwing objects. Read these safety rules and follow them closely. Failure to obey these rules could result in loss of control of unit, severe personal injury or death to you, or bystanders, or damage to property or equipment. The triangle  in text signifies important cautions or warnings which must be followed.

## TRAINING

1. Read, understand, and follow all instructions on the machine and in the manuals before operating this unit. Be thoroughly familiar with the controls and the proper use of the equipment. Know how to stop the unit and disengage the controls quickly.
2. Never allow children to operate the equipment. Never allow adults to operate the equipment without proper instruction.
3. Keep the area of operation clear of all persons, particularly small children and pets.

## PREPARATION

1. Thoroughly inspect the area where the equipment is to be used and remove all doormats, sleds, boards, wires, and other foreign objects.
2. Disengage all clutches and shift into neutral before starting engine (motor).
3. Do not operate the equipment without wearing adequate winter outer garments. Avoid loose fitting clothing that can get caught in moving parts. Wear footwear that will improve footing on slippery surfaces.
4. Handle fuel with care; it is highly flammable.
  - (a) Use an approved fuel container.
  - (b) Never add fuel to a running engine or hot engine.
  - (c) Fill fuel tank outdoors with extreme care. Never fill fuel tank indoors. Replace fuel cap securely and wipe up spilled fuel.
  - (d) Never fill containers inside a vehicle or on a truck or trailer bed with a plastic liner. Always place containers on the ground, away from your vehicle, before filling.
  - (e) When practical, remove gas-powered equipment from the truck or trailer and refuel it on the ground. If this is not possible, then refuel such on a trailer with a portable container, rather than from a gasoline dispenser nozzle.
  - (f) Keep nozzle in contact with the rim of the fuel tank or container opening at all times, until refueling is complete. Do not use a nozzle lock-open device.
  - (g) Replace gasoline cap securely and wipe up spilled fuel.
  - (h) If fuel is spilled on clothing, change clothing immediately.
5. Adjust the collector housing height to clear gravel or crushed rock surfaces.
6. Never attempt to make any adjustments while the engine (motor) is running (except when specifically recommended by the manufacturer).
7. Let engine (motor) and machine adjust to outdoor temperatures before starting to clear snow.
8. Always wear safety glasses or eye shields during operation or while performing an adjustment or repair to protect eye from foreign objects that may be thrown from the machine.

## OPERATION

1. Do not put hands or feet near or under rotating parts. Keep clear of the discharge opening at all times.
2. Exercise extreme caution when operating on or crossing gravel drives, walks, or roads. Stay alert for hidden hazards or traffic. Do not carry Passengers.
3. After striking a foreign object, stop the engine (motor), remove the wire from the spark plug, disconnect the cord on electric motors, thoroughly inspect the snowthrower for any damage, and repair the damage before restarting and operating the snowthrower.
4. If the unit should start to vibrate abnormally, stop the engine (motor) and check immediately for the cause. Vibration is generally a warning of trouble.
5. Stop the engine (motor) whenever you leave the operating position, before unclogging the collector/impeller housing or discharge guide, and when making any repairs, adjustments, or inspections.
6. When leaving the machine unattended, disengage the power take-off (PTO), lower the attachment, set the parking brake, stop the engine, and remove the key.
7. When cleaning, repairing, or inspecting make certain the collector/impeller and all moving parts have stopped. Disconnect the spark plug wire and keep the wire away from the plug to prevent accidental starting. Do not run the engine indoors except for starting the engine or for transporting the snowthrower in or out of the building. Open the outside doors; exhaust fumes are dangerous.
8. Exercise extreme caution when operating on slopes. Do not attempt to clear steep slopes.
9. Never operate the snowthrower without proper guards plates, or other safety protective devices in place and working.
10. Never direct the discharge toward people or areas where property damage can occur. Keep children and others away.
11. Do not overload the machine capacity by attempting to clear snow at too fast a rate.
12. Never operate the machine at high transport speeds on slippery surfaces. Look behind and use care when operating in reverse.
13. Disengage power to the collector/impeller when snowthrower is transported or not in use.
14. Use only attachments and accessories approved by the manufacturer of the snowthrower (such as wheel weights, counterweights, or cabs).
15. Never operate the snowthrower without good visibility or light. Always be sure of your footing, and keep a firm hold on the handles. Walk, never run.
16. Never touch a hot engine or muffler.
17. Never operate the snowthrower near glass enclosures, automobiles, window wells, drop-offs, and the like without proper adjustment of the discharge angle.
18. Never direct discharge at bystanders or allow anyone in front of the unit.

19. Never leave a running unit unattended. Always disengage the auger and traction controls, stop engine, and remove keys.
20. Do not operate the unit while under the influence of alcohol or drugs.
21. Keep in mind the operator is responsible for accidents occurring to other people or property.
22. Data indicates that operators, age 60 years and above, are involved in a large percentage of power equipment-related injuries. These operators should evaluate their ability to operate the unit safely enough to protect themselves and others from injury.
23. DO NOT wear long scarves or loose clothing that could become entangled in moving parts.
24. Snow can hide obstacles. Make sure to remove all obstacles from the area to be cleared.
7. Always observe safe refueling and fuel handling practices when refueling the unit after transportation or storage.
8. Always follow the engine manual instructions for storage preparations before storing the unit for both short and long term periods.
9. Always follow the engine manual instructions for proper start-up procedures when returning the unit to service.
10. Maintain or replace safety and instruction labels as necessary.
11. Keep nuts and bolts tight and keep equipment in good condition.
12. Never tamper with safety devices. Check their proper operation regularly and make necessary repairs if they are not functioning properly.
13. Components are subject to wear, damage, and deterioration. Frequently check components and replace with manufacturer's recommended parts, when necessary.
14. Check control operation frequently. Adjust and service as required.
15. Use only factory authorized replacement parts when making repairs.
16. Always comply with factory specifications on all settings and adjustments.
17. Only authorized service locations should be utilized for major service and repair requirements.
18. Never attempt to make major repairs on this unit unless you have been properly trained. Improper service procedures can result in hazardous operation, equipment damage and voiding of manufacturer's warranty.
19. Check shear bolts and other bolts at frequent intervals for proper tightness to be sure the equipment is in safe working condition.

## CHILDREN

Tragic accidents can occur if the operator is not alert to the presence of children. Children are often attracted to the unit and the operating activity. Never assume that children will remain where you last saw them.

1. Keep children out of the area and under the watchful care of another responsible adult.
2. Be alert and turn unit off if children enter the area.
3. Never allow children to operate the unit.
4. Use extra care when approaching blind corners, shrubs, trees, or other objects that may obscure vision.

## CLEARING A CLOGGED DISCHARGE CHUTE

Hand contact with the rotating impeller inside the discharge chute is the most common cause of injury associated with snowthrowers. Never use your hand to clean out the discharge chute.

To clear the chute:

1. SHUT OFF THE ENGINE.
2. Wait 10 seconds to be sure the impeller blades have stopped rotating.
3. Always use a clean out tool, not your hands.

## SERVICE, MAINTENANCE, AND STORAGE

1. Check shear bolts and other bolts at frequent intervals for proper tightness to be sure the equipment is in safe working condition.
2. Never store the machine with fuel in the fuel tank inside a building where ignition sources are present such as hot water and space heaters, or clothes dryers. Allow the engine to cool before storing in any enclosure.
3. Always refer to the operator's manual for important details if the snowthrower is to be stored for an extended period.
4. Maintain or replace safety and instruction labels as necessary.
5. Run the machine a few minutes after throwing snow to prevent freeze-up of the collector/impeller.
6. If fuel is spilled, do not attempt to start the engine but move the machine away from the area of spillage and avoid creating any source of ignition until fuel vapors have dissipated.

## EMISSIONS

1. Engine exhaust from this product contains chemicals known, in certain quantities, to cause cancer, birth defects, or other reproductive harm.
2. If available, look for the relevant Emissions Durability Period and Air Index information on the engine emissions label.

# Safety Decals

## SAFETY DECALS

This unit has been designed and manufactured to provide you with the safety and reliability you would expect from an industry leader in outdoor power equipment manufacturing.

Although reading this manual and the safety instructions it contains will provide you with the necessary basic knowledge to operate this equipment safely and effectively, we have placed several safety labels on the unit to remind you of this important information while you are operating your unit.

All DANGER, WARNING, CAUTION and instructional messages on your unit should be carefully read and obeyed. Personal bodily injury can result when these instructions are not followed. The information is for your safety and it is important! The safety decals below are on your unit.

If any of these decals are lost or damaged, replace them at once. See your local dealer for replacements.

These labels are easily applied and will act as a constant visual reminder to you, and others who may use the equipment, to follow the safety instructions necessary for safe, effective operation.



Part No. 1716532  
Auger Danger Decal

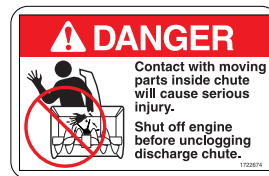

Part No. 1722674  
Discharge Chute Danger Decal



Part No. 1716531  
Main Operation Warning Decal



Part No. 1716540  
Rear Wheel Weights Required

### Required Accessories

It is required that tire chains and two rear wheel weights or Quick Tach Weights are used.

**Never operate on slopes greater than 17.6% (10°).**

### Recommended Accessories

A rear-mounted weight box can also be added for additional traction. The maximum weight added to the tractor should not exceed 35 lbs. per wheel, plus 100 additional pounds in the rear weight box.

For operation on slopes greater than 15% (8.5°), Quick Tach Weights, tire chains, and wheel weights are recommended. **Never operate on slopes greater than 17.6% (10°).**

### Required Accessories

A Lift Lever Kit is required for some of the models covered by this manual, and must be installed as part of hitch installation.



### TRACTOR CONTROLS

Before you begin operating the tractor and attachment, make certain you have:

- **Read and understood the instructions in the tractor Operator's Manual.**
- **Become thoroughly familiar with all of the tractor controls and their operation, including how to safely and properly start and stop the unit.**
- **Practice driving in an open area, without the attachment, to become accustomed to the unit.**

### DANGER

**Do not clean out discharge chute with hands. Contact with moving parts inside chute will cause serious injury. Use a clean out tool. Use the following procedure to remove objects or clear the chute:**

1. Stop the engine. Remove the key
2. Wait 10 seconds to be sure the auger/impeller blades have stopped rotating.
3. Always use a clean-out tool. **DO NOT** use your hands.

## CONTROL FUNCTIONS

The information below briefly describes the function of individual controls. Operating the tractor and attachment requires the combined use of these controls and additional controls whose operation is described in the tractor Operator's Manual.

Please take a moment and familiarize yourself with the name, location, and function of these controls so that you will better understand the safety and operating instructions provided in this manual.

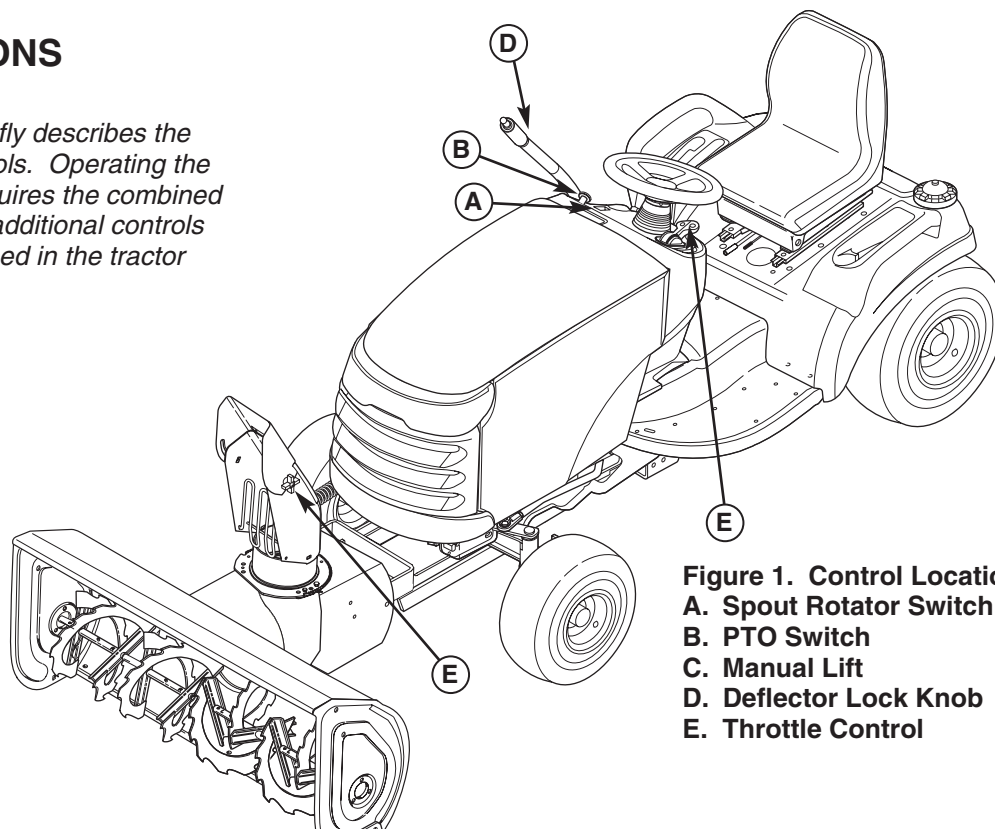

**Figure 1. Control Locations**  
A. Spout Rotator Switch  
B. PTO Switch  
C. Manual Lift  
D. Deflector Lock Knob  
E. Throttle Control

### A. Electric Spout Rotator Switch

Controls the electric spout rotator.

### B. PTO Switch

Engages and disengages the PTO to start and stop the snowthrower.

### C. Manual Attachment Lift Lever

The attachment lift lever raises and lowers the attachment. To RAISE an attachment, depress the release button on top of the lever and pull back. To LOWER an attachment, depress the release button and move the lever forward. When lowering the attachment, be sure to push the lever fully forward into the locked position.

### D. Deflector Lock Knob

The snowthrower discharge deflector angle can be changed by loosening the lock knob, changing the deflector angle and tightening the lock knob.

### E. Throttle Control

Always operate at FULL throttle.



## TRACTOR CONTROLS

Before you begin operating the tractor and attachment, make certain you have:

- Read and understood the instructions in the tractor Operator's Manual.
- Become thoroughly familiar with all of the tractor controls and their operation, including how to safely and properly start and stop the unit.
- Practice driving in an open area, without the attachment, to become accustomed to the unit.





# General Operating Instructions

## WARNING

If auger does not start and stop when engaging/disengaging electric clutch, see your authorized dealer. Under no circumstances should you attempt to defeat the safety system.

### Checks Before Starting

**IMPORTANT NOTE:** Refer to Tractor Operator's Manual for important information concerning safely storing your tractor.

1. Refer to the Maintenance & Adjustments sections of this manual and perform any needed service. Also, refer to the tractor Operator's Manual and perform any required service.
2. Remove any objects from the work area which might be caught in, or thrown by, the auger.
3. Before starting the engine, clear the auger of any ice particles which may cause damage to auger.
4. Adjust the deflector and skid shoes to desired height. See Skid Shoe Adjustment and Deflector Adjustment.
5. Make sure all hardware is present and secure.

### Engine & Ground Speed Selection

Always run the engine at full throttle.

Normally, a slow ground speed is best for throwing snow. The deeper or heavier the snow, the slower the recommended ground speed.

### Starting & Stopping

1. Start the tractor engine. Set engine throttle FULL.
2. Lower the snowthrower.
3. Engage the electric clutch switch. Snowthrower auger should rotate. Disengage the electric clutch switch. Snowthrower auger should stop.
4. Adjust the throttle to full speed. Select the proper ground speed.
5. To stop tractor movement, depress the clutch/brake pedal. To stop the snowthrower, disengage the electric clutch. Before leaving the seat, disengage the electric clutch, set the parking brake, stop the engine, remove the key, and wait for all moving parts to stop.

## WARNING

Perform the Safety System Interlock test found in your tractor Operator's Manual. If tractor does not pass the test, do not operate the tractor. See your authorized dealer. Under no circumstances should you attempt to defeat the safety system.

Use caution when clearing a snow covered area. Snow can cover objects such as curbs, drop-offs, and other obstacles. Be familiar with the area you are clearing.

To prevent an explosion or fire, never store the tractor with fuel in the tank inside a building where an ignition source is present.



### IMPORTANT NOTE

Always raise the snowthrower before turning or backing up to prevent damage to the unit.

## DANGER

### OPERATING ON SLOPES CAN BE DANGEROUS

Never operate on slopes greater than 17.6% (10°) which is a rise of 3-1/2 feet (106cm) vertically in 10 feet (607cm) horizontally.

Operate the unit at a slow ground speed when driving onto slope. Avoid using brakes to control ground speed.

When operating on slopes that are greater than 15 % (8.5°) but less than 17.6%, use additional wheel weights or counterweights.

In addition to counterweights, use extra caution when operating on slopes. Drive UP and DOWN the slope, never across the face, use caution when changing directions and DO NOT START OR STOP ON SLOPE.

For additional traction, tire chains and a weight box can be added. Maximum weight added to tractor should not exceed 50 lbs. per wheel and 100 additional lbs. in weight box.

### Transporting

1. Disengage the electric clutch and then raise the snowthrower.
2. Adjust ground speed according to surface conditions.
3. Select a low ground speed when transporting on a slippery surface.

# General Operating Instructions

---

## Snow Removal Suggestions

- Determine the best snow removal pattern before beginning.
- Wind direction is an important factor to consider. Rotate the spout to discharge snow downwind.
- Plan the pattern so that you avoid throwing snow on cleared areas and on yourself as you are operating.
- When land contour permits, it is best to travel in the longest direction to minimize turning.
- In very deep or heavy snow, it may be necessary to make the first pass with snowthrower partially raised, backing up every few feet and lowering the snowthrower to clear the snow left on the surface. Also, it may be necessary to slice off less than the full width of the auger or reduce ground speed.
- If snow stops flowing freely from the spout, back away until the snowthrower clears itself.

## DANGER

**If the auger stalls or the chute plugs, DISENGAGE THE ELECTRIC CLUTCH, STOP THE ENGINE AND REMOVE THE KEY. SET THE PARKING BRAKE. WAIT FOR MOVING PARTS TO STOP. Remove the foreign object or clear the spout with a piece of wood before restarting the engine. Never place hands into auger housing or spout to clear jammed object. Auger may rotate when object is removed.**

## Daily Storage

1. Run the snowthrower a few minutes after blowing snow to prevent freeze-up of auger.
2. Allow tractor engine to cool before storing in any enclosure.

## Off-Season Storage

1. Remove snowthrower from the tractor.
2. Use water pressure or a brush to thoroughly clean the housing.
3. Paint, or lightly coat with oil, any area where paint has been worn or chipped away.
4. Lubricate the snowthrower.
5. Store the snowthrower and hitch in a dry place.

## **⚠ WARNING**

To avoid serious injury, perform maintenance on the unit only when the engine is stopped and all moving parts have stopped. Always remove the ignition key before beginning maintenance or adjustments to prevent accidental starting of the engine.

### Schedule For Normal Care

Care Required	Schedule
Clean snow and ice from snowthrower.	After each use.
Lubricate snowthrower.	Every 10 hours or at least once a year.

### General Lubrication

Lubricate the snow thrower as shown in Figure 2. Where an oil can is shown use 30 weight oil. Where a grease gun is shown, use lithium grease. Lubricate the following areas:

- Oil the chute deflector.
- Grease the chute ring gear.
- Grease the snow thrower-hitch pivot points.
- Grease the auger shaft grease fittings.

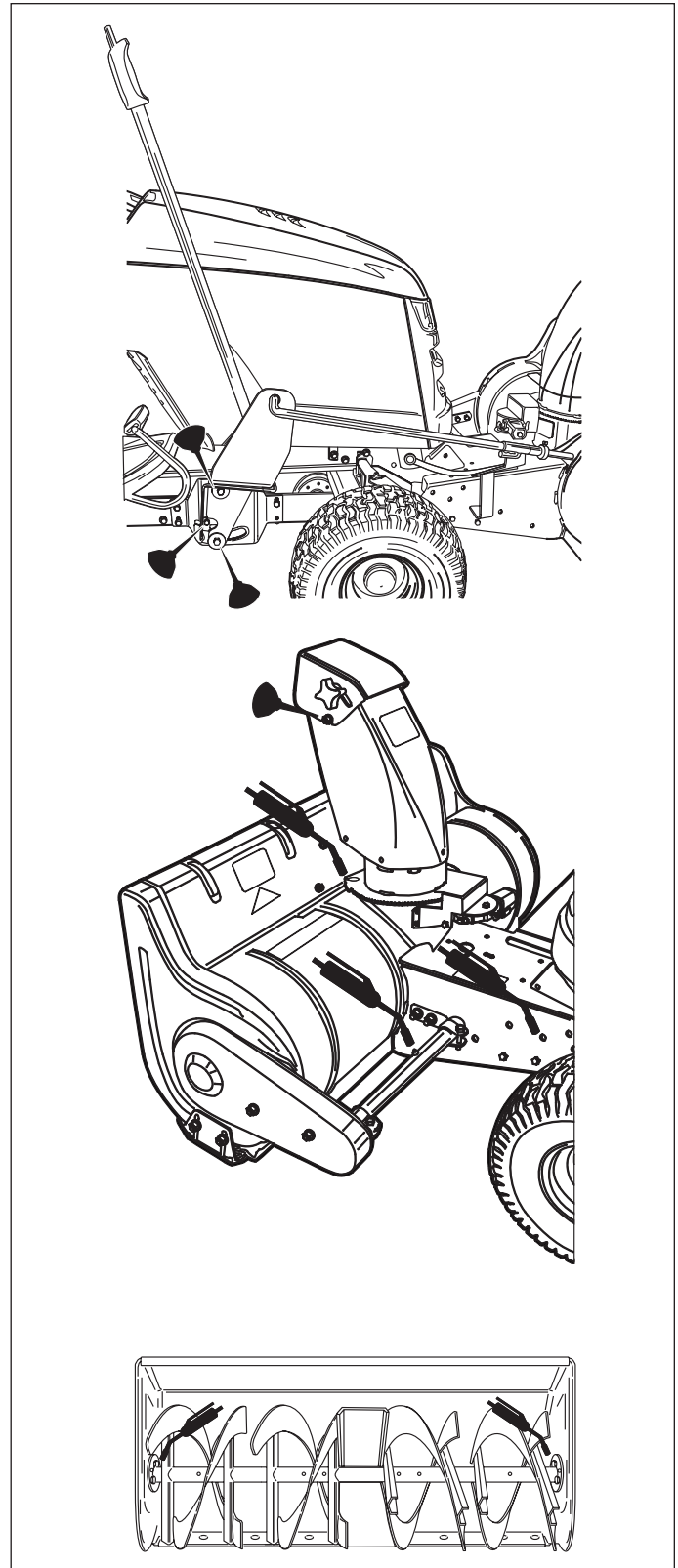

**Figure 2. Lubrication Points**

# Troubleshooting, Adjustments, & Service



## TROUBLESHOOTING

While normal care and regular maintenance will extend the life of your equipment, prolonged or constant use may eventually require that service be performed to allow it to continue operating properly.

The troubleshooting guide below lists the most common problems, their causes and remedies. See the information on the following pages for instructions on how to perform most of these minor adjustments and service repairs yourself. If you prefer, all of these procedures can be performed for you by your local authorized dealer.

## WARNING

**To avoid serious injury, perform maintenance on the tractor or snow thrower only when the engine is stopped and the parking brake engaged. Always remove the ignition key, disconnect the spark plug wire and fasten it away from the plug before beginning the maintenance, to prevent accidental starting of the engine.**

PROBLEM	CAUSE/SOLUTION
1 Snow thrower auger does not rotate.	A. Electric clutch not engaged. Engage electric clutch. B. Foreign material is blocking auger. <b>STOP</b> engine. Remove key. Unplug auger with piece of wood. Read <b>WARNING</b> on page 5. C. Drive chain broken. Replace parts as required.
2 Auger does not stop when electric clutch is disengaged.	A. Electric clutch brake not operating properly. See your dealer.
3 Auger rotates, but snow is not thrown far enough.	A. Engine RPM too slow. Set throttle to <b>FULL</b> . B. Ground speed too fast. Use slow ground speed. C. Snow thrower discharge chute clogged. <b>STOP</b> engine. Remove key. Unplug discharge chute using the chute cleaning tool or a piece of wood. Read <b>WARNING</b> on page 5.
4 Scraper bar does not clean down to hard surface.	A. Skid shoes not properly adjusted. Adjust skid shoes. B. Lift height out of adjustment. See <b>ADJUSTMENTS</b> section. C. No down pressure. See Hitch Installation Instructions.
5 Snow thrower picks up and throws stones on gravel drive.	A. Skid shoes not properly adjusted for ground surface. Adjust skid shoes. B. Too much downward pressure on snow thrower. Raise snow thrower slightly.
6 Tractor does not have sufficient traction.	A. Tractor too light at rear wheels. Use Quick Tach weights, wheel weights, and tire chains.
7 Tractor not stable on sloping surfaces.	A. Ground speed too fast. Reduce speed. B. Tractor not properly weighted. See Recommended Accessories, page 1. C. Slope grade too steep. See Safety Section. Use Quick Tach weights, wheel weights, and tire chains.
8 Chute does not rotate.	A. Rotator gears out of adjustment. B. Wire harness disconnected.

### Skid Shoe Adjustment

On smooth surfaces such as concrete or asphalt, the scraper bar should scrape the surface. On surfaces such as gravel, the scraper bar should be set high enough so that it will not pick up debris.

1. Loosen the nuts securing the skid shoes (see Figure 3).
2. Raise or lower the scraper bar to the desired height. Use wood blocks to hold the snow thrower in position.
3. Set the skid shoes so that they are in contact with the ground and tighten the skid shoe nuts.

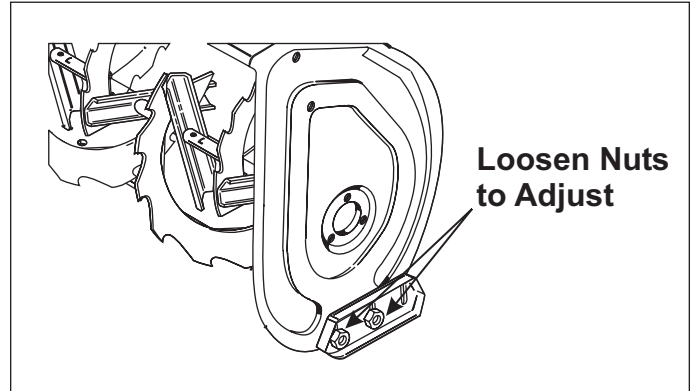

Figure 3. Adjusting Skid Shoes

### Electric Chute Rotator Gear

1. Remove the cover and loosen the three screws (B, Figure 4) securing the electric chute rotator motor.
2. Adjust the motor (C) so that the gear (A) meshes with the discharge chute ring gear and tighten the adjustment screws (B).
3. Reinstall the cover.

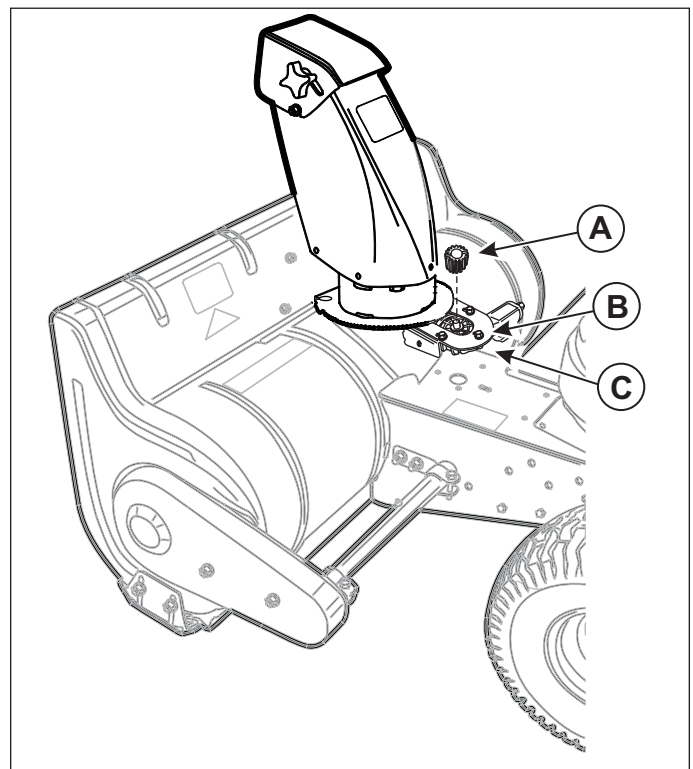

Figure 4. Chute Rotator Gear

# Troubleshooting, Adjustments, & Service

## Lift Adjustment

In the fully raised position the attachment should be 4"-5" off the ground.

### LIFT HEIGHT ADJUSTMENT

1. Fully raise the attachment lift. The snow thrower should be approximately 4"-5" off the ground. If not, go to step 2.
2. Lower the snow thrower and adjust the front set collar (A, Figure 5) to achieve the correct lift height.

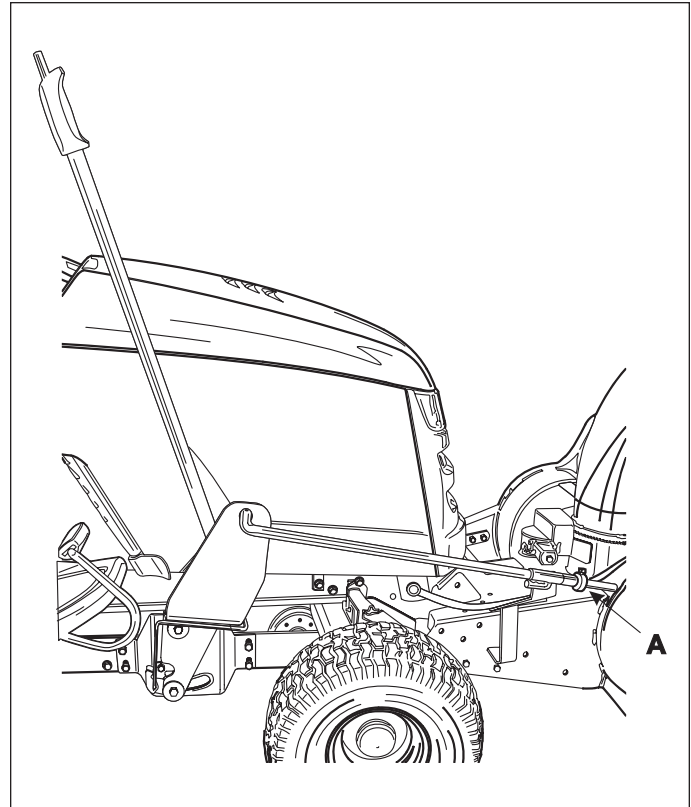

Figure 5. Height Adjustment Collar

## Belt Tension Adjustment

Adjust belt tension if the tension lever does not adjust belt tension properly.

1. Loosen bolt (A, Figure 6) on idler pulley (D), located on the left side of the hitch assembly.
2. Move belt tension lever to the released position (C).
3. Move idler pulley (D) backwards or forwards to adjust snow thrower drive belt tension.
4. Move belt tension lever to the locked tension position (B).
5. Test snow thrower and repeat adjustment as needed.

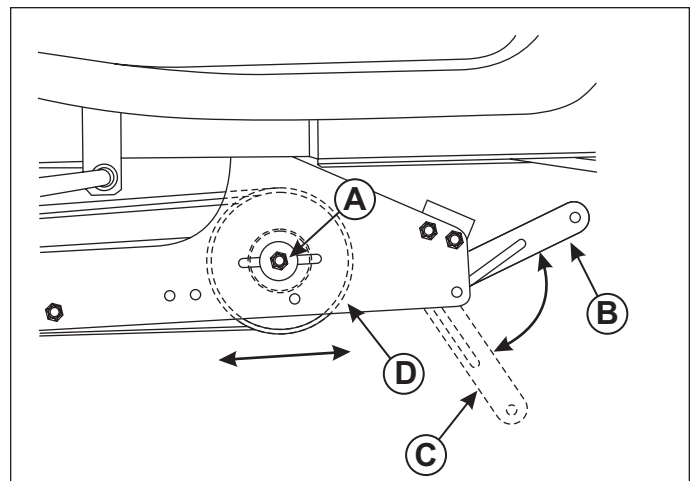
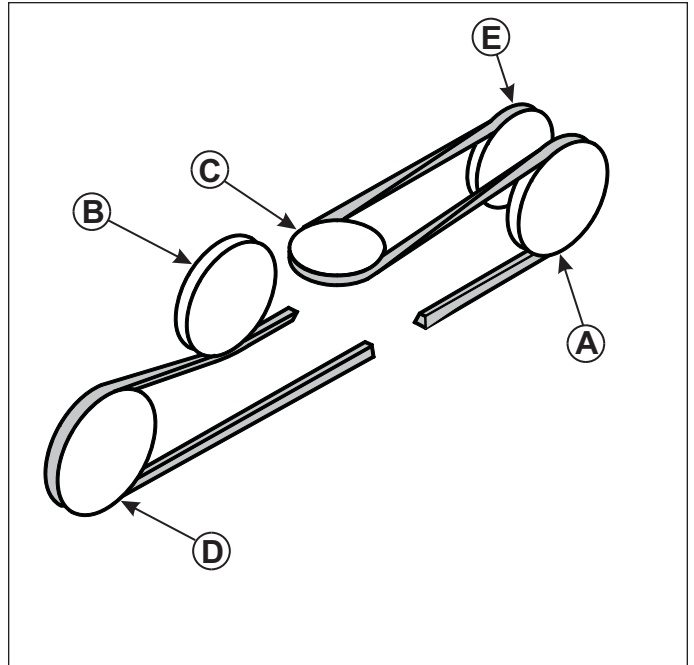

Figure 6. Belt Tension Adjustment

- A. Idler Pulley Bolt
- B. Belt Tension Lever – Locked Position
- C. Belt Tension Lever – Tension Released Position
- D. Idler Pulley

### Belt Replacement

1. Move tension release lever to the released position (C, Figure 6).
2. Remove the belt from the snow thrower pulley (D, Figure 7).
3. Remove the belt from the machine.
4. Install the new belt as shown in Figure 7.
5. Move the belt tension lever to the locked position (B, Figure 6).

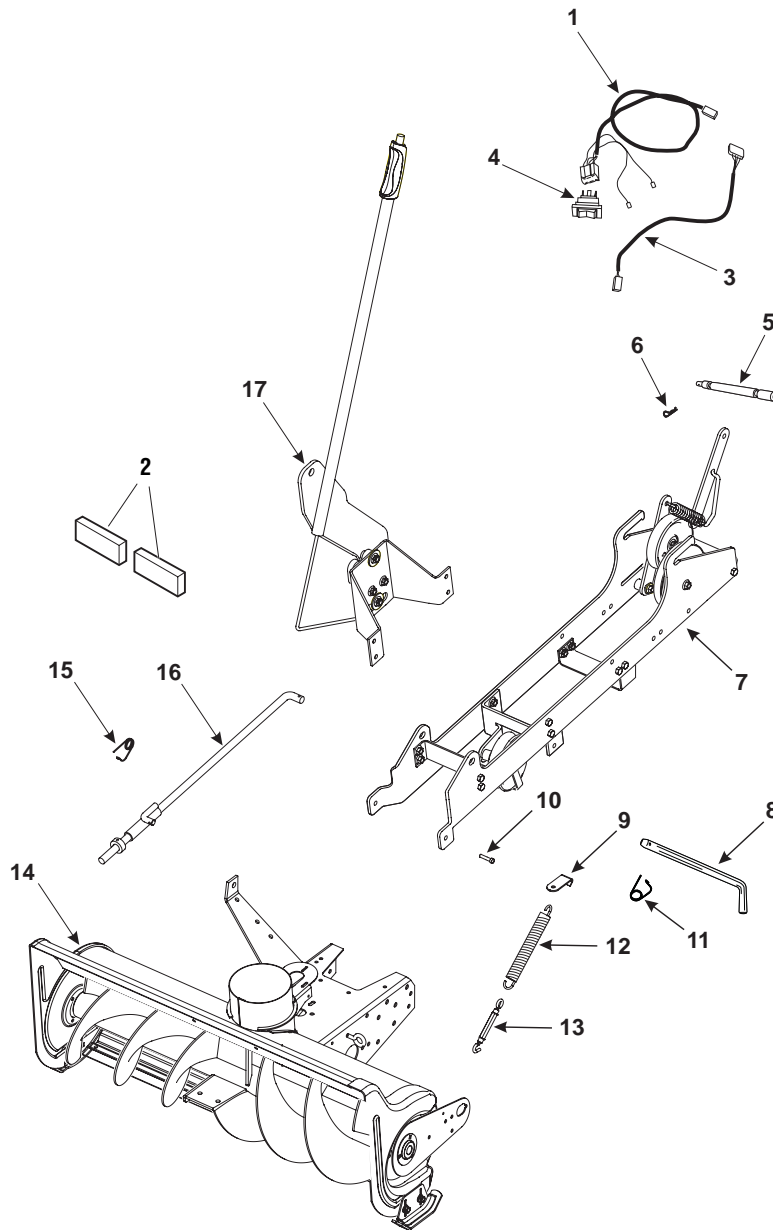

**Figure 7. Belt Routing**

- A. V-Pulley
- B. Idler Pulley
- C. Electric Clutch Pulley (V-pulley)
- D. Snow thrower Pulley (V-pulley)
- E. Idler Pulley

# Initial Setup & Assembly

Setup



Ref	Qty	Description	Ref	Qty	Description
1	1	UPPER WIRING HARNESS	10	2	MOUNTING PINS
2	2	REFLECTORS	11	1	QUICK CLIP
3	1	FINAL WIRING HARNESS	12	1	SPRING
4	1	CHUTE ROTATION SWITCH	13	1	TURN BUCKLE
5	1	HITCH SUPPORT SHAFT	14	1	BLOWER ASSEMBLY
6	1	HAIR PIN COTTER	15	4	QUICK CLIPS
7	1	HITCH ASSEMBLY	16	1	LIFT ARM LINKAGE
8	1	HITCH LATCH PIN	17	1	LIFT ARM ASSEMBLY
9	1	AXLE CLIP	18	1	CHUTE ASSEMBLY (not shown)

Figure 8. Initial Setup



## CHUTE ASSEMBLY

1. Carefully unpack and organize Snow thrower parts.
2. Remove chute rotator drive cover (B, Figure 9) from the snow thrower assembly by removing hex screw (A) and tilting the gearbox cover to disengage tab on opposite side of box.
3. Remove chute rotator gear from shaft (C). Note location of notch (D) in chute ring gear. Align the notch in the chute assembly with the guide tab at the base of the discharge outlet.
4. Slide chute (E) into place and rotate chute 180 degrees to front.

*Note: Chute opening should be facing front/center of machine.*

5. Replace chute rotator gear (A, Figure 10) onto shaft and rotate to align chute ring gear and drive gear.
6. Loosen, but do not remove the 3 hex bolts (B) holding chute rotator drive assembly to the snow thrower.
7. Move chute rotator drive assembly (C) toward chute until the chute ring gear meshes with the rotation motor drive gear. Tighten the 3 hex bolts.
8. Replace chute gearbox cover over rotator (B, Figure 9) gear mechanism and secure with the hex bolt.

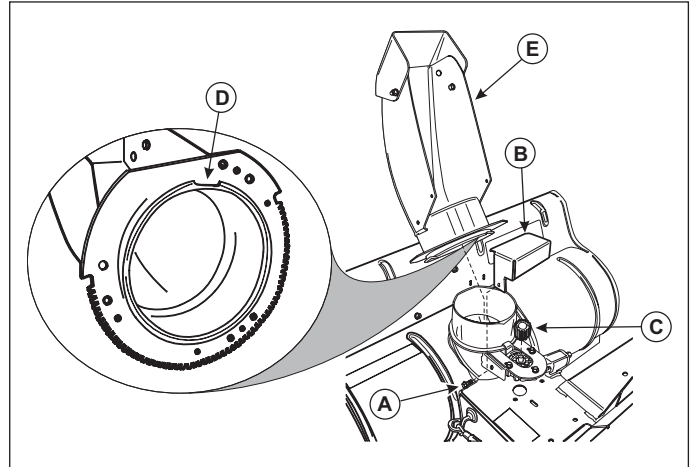

**Figure 9. Chute Assembly**  
**A. Chute Rotator Drive Cover Bolt**  
**B. Chute Rotator Drive Cover**  
**C. Chute Rotator Drive Assembly**  
**D. Chute Assembly Notch**  
**E. Chute Assembly**

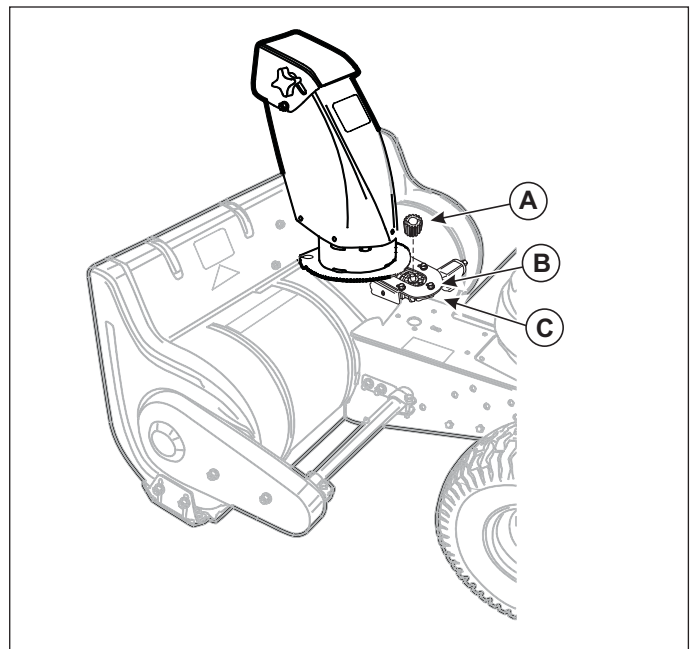

**Figure 10. Chute Assembly**  
**A. Chute Rotator Gear**  
**B. Hex Bolts**  
**C. Chute Rotator Drive Assembly**

# Initial Setup & Assembly

## INSTALL HITCH ONTO TRACTOR

1. Remove mower deck.
2. Place hitch on floor in front of tractor, with the hitch mounting arms towards the rear of the tractor.

*NOTE: If this is a new installation, cut the plastic ties holding the snow thrower drive belt for shipping, but do not remove the belt.*

3. On underside of tractor frame, insert hitch support shaft (A, Figure 11) as shown and secure, with the hair pin cotter pin (B) on inside of frame. **IMPORTANT** – the hair pin cotter pin must be located along the inside edge of the tractor frame.
4. Slide hitch (A, Figure 12) under tractor and lift to slide hitch mounting arms (C) over hitch support shaft (B).
5. At front of the machine, locate and remove the hitch latch pin (A, Figure 13) from the hitch assembly (B).
6. Turn the front wheels fully to the left.

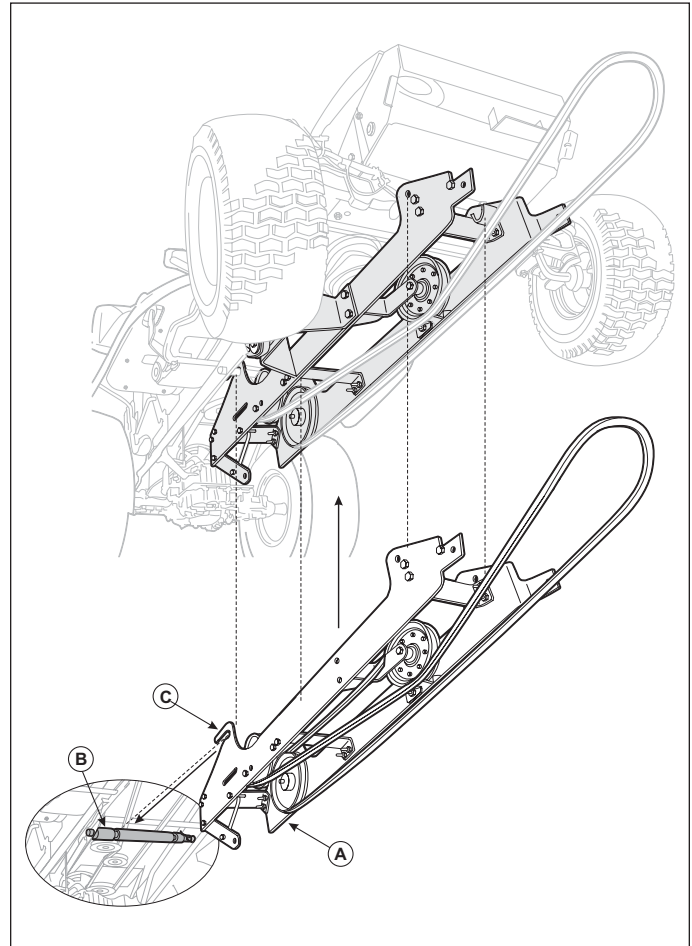

**Figure 12. Hitch Installation**

- A. Hitch Assembly
- B. Hitch Support Shaft
- C. Hitch Mounting Arms

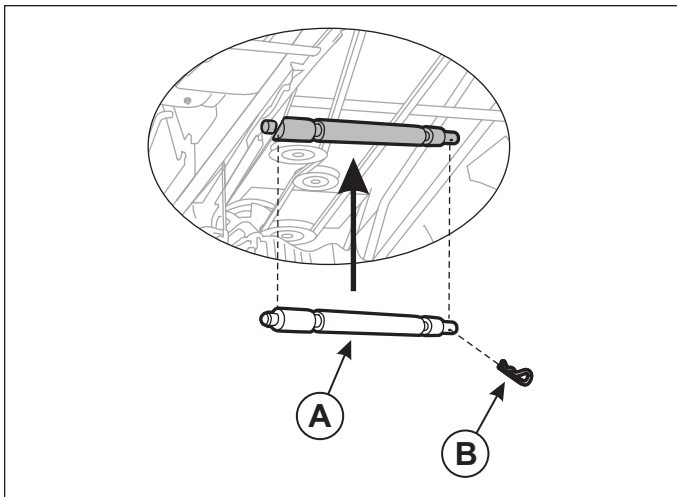

**Figure 11. Install Hitch Support Shaft**

- A. Hitch Support Shaft
- B. Hair Pin Cotter

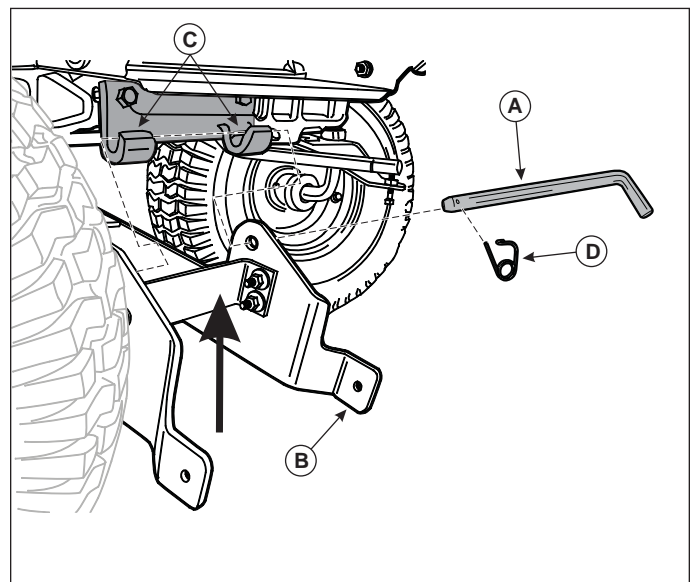

**Figure 13. Hitch Latch Pin Installation**

- Lift the hitch (B) and from the left side of the tractor, slide hitch latch pin (A) through the mounting hole in hitch frame, along the tractor frame support fingers (C) and through the final mounting hole in hitch frame. Secure hitch latch pin (A) with the quick clip (D).

*NOTE: Keep the handle portion of the hitch latch pin towards the front of the tractor.*

- Hitch installation is now complete.

## ATTACHING BLOWER TO TRACTOR

- Position snow thrower assembly in front of tractor.
- Remove both quick clips (E, Figure 14) and mounting pins (D) from the snow thrower.
- Align the hitch mounting arms (B) with the snow thrower mounting tabs (C) and slide the snow thrower into position.
- Align mounting holes on snow thrower frame with the mounting holes in the hitch.
- Insert mounting pins (D) and secure with quick clips (E).
- Locate the belt tension lever (B, Figure 15) at the rear of the hitch assembly and rotate it into the released position (A).
- Install the drive belt onto the snow thrower drive pulley (D, Figure 16) and then onto the tractor PTO (C). See Belt Installation Diagram (Figure 16)

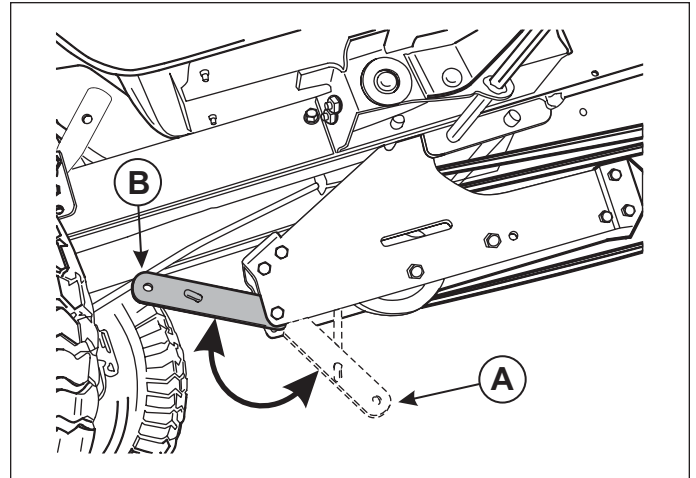

**Figure 15. Belt Tension Lever**  
**A. Belt Tension Lever – Released Position**  
**B. Belt Tension Lever – Tension Position**

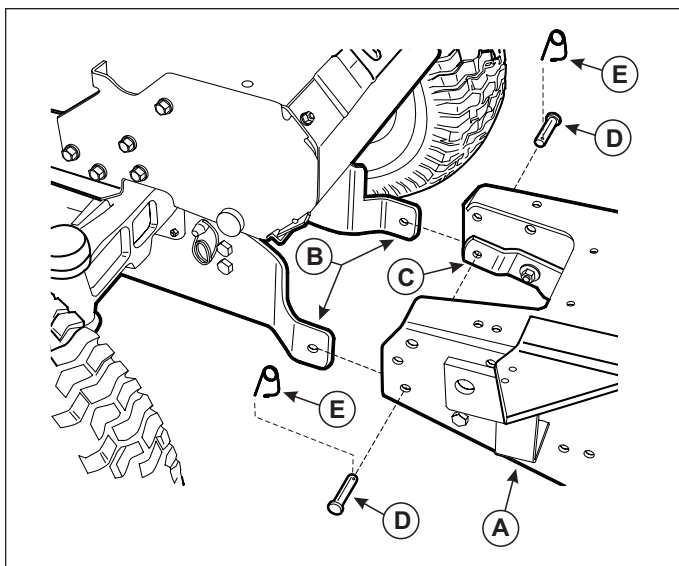

**Figure 14. Snow Thrower Installation**  
**A. Snow Thrower Assembly**  
**B. Hitch Mounting Arms**  
**C. Snow Thrower Mounting Tabs**  
**D. Mounting Pins**  
**E. Quick Clips**

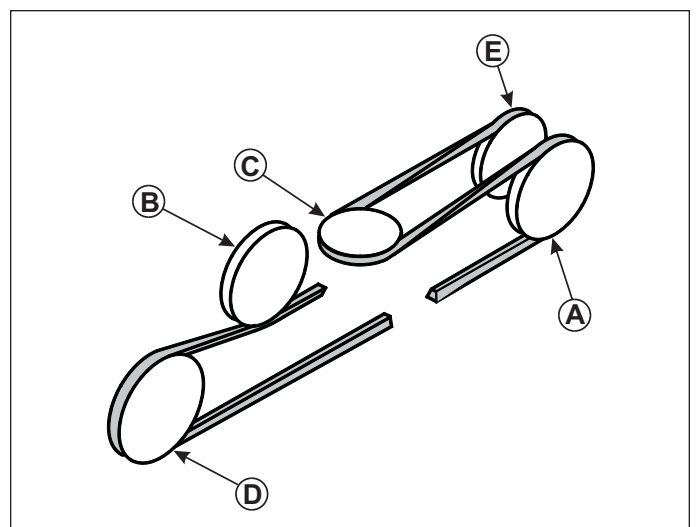

**Figure 16. Belt Installation Diagram**  
**A. V-Pulley**  
**B. Idler Pulley**  
**C. PTO Pulley**  
**D. Snow Thrower Pulley**  
**E. Idler Puller**

## Initial Setup & Assembly

8. Rotate the belt tension lever upwards into the locked position (B, Figure 15), fully tensioning the snow thrower drive belt.

*NOTE: Do not connect the mower deck lift arm or cable to the belt tension lever.*

### ATTACHING LIFT ARM ASSEMBLY TO TRACTOR

1. On right side of tractor, remove the four (4) hex bolts and nuts (B, Figure 17) from hitch assembly.
2. Attach lift arm assembly (A) to the tractor frame using the four hex bolts (B) and nuts.
3. Install Lift Arm linkage (C) as shown and secure with quick clips (D).
4. Adjust the lifting collar (E) to make sure that the snow thrower is lifted clear of the ground for transportation.
5. Assemble lift assist parts; attach spring (B, Figure 18) to turnbuckle (C) and axle clamp (A).

*NOTE: Make sure to position the axle clamp (E) so that it does not contact the axle rib (F) and fully seats on the axle.*

6. Fully raise the snow thrower off the ground.
7. Attach open end of turnbuckle to eye-bolt (D) on blower assembly and the spring (B) as shown.
8. Adjust spring tension by rotating the turnbuckle until threads bottom out on both sides.
9. Remove the skid shoes from the snowthrower and rotate them from the shipping position to the normal use position. Adjust the skid shoes for proper snow removal. See Troubleshooting, Adjustments and Service for skid shoe adjustment procedures.

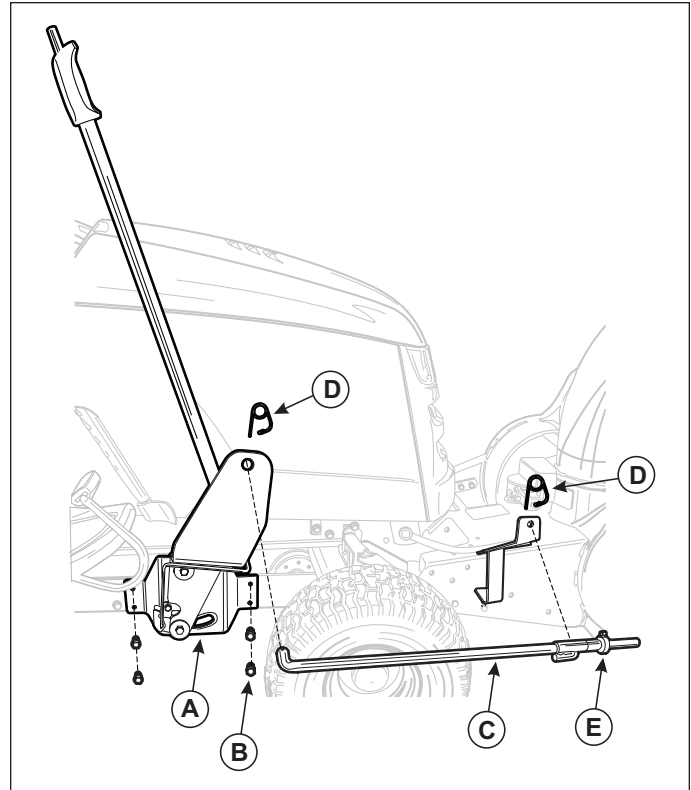

**Figure 17. Lift Arm and Linkage**

- A. Lift Arm Assembly**
- B. Mounting Bolts and Nuts**
- C. Lift Arm Linkage**
- D. Quick Clip**
- E. Lifting Collar**

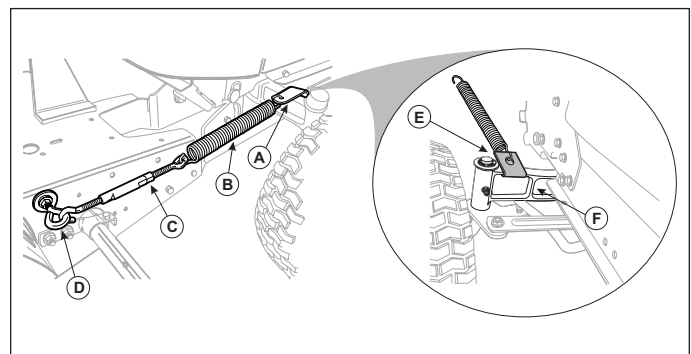

**Figure 18. Lift Assist Spring Assembly**

- A. Axle Clamp**
- B. Spring**
- C. Turnbuckle**
- D. Eye-bolt**
- E. Axle Clamp**
- F. Axle Rib**

## ATTACHING CHUTE MOTOR WIRING HARNESS

1. Wiring Harness is in four (4) parts.
  - a. Switch
  - b. Upper wiring harness with main power connector
  - c. Final wiring harness with a square connector on each end.
2. Remove plug from tractor control panel at position shown and install the chute rotation switch (A, Figure 19).
3. Plug female receptacle (B, Figure 19) end of the upper wiring harness onto switch.
4. Route the upper wiring harness (B, Figure 19) down through the right side of the panel enclosure, locating the square connector in front of the firewall, along the tractor frame.
5. Locate the power leads (Red with yellow stripe and black) in the tractor wiring harness at the base of steering column. Connect the wiring harness power leads (B, Figure 20), color to color, to the chute rotation wiring harness spade connectors.
6. Connect the final wiring harness (B, Figure 20) to the upper wiring harness (A) using the square connector and then to the chute rotation motor connector (D). Position the wiring heat cover underneath the tractors muffler. Loosely secure the final wire harness (B) to the lift arm linkage (C, Figure 23)

## Install Reflectors

1. Install the two reflectors on the rear of the tractor seat deck.

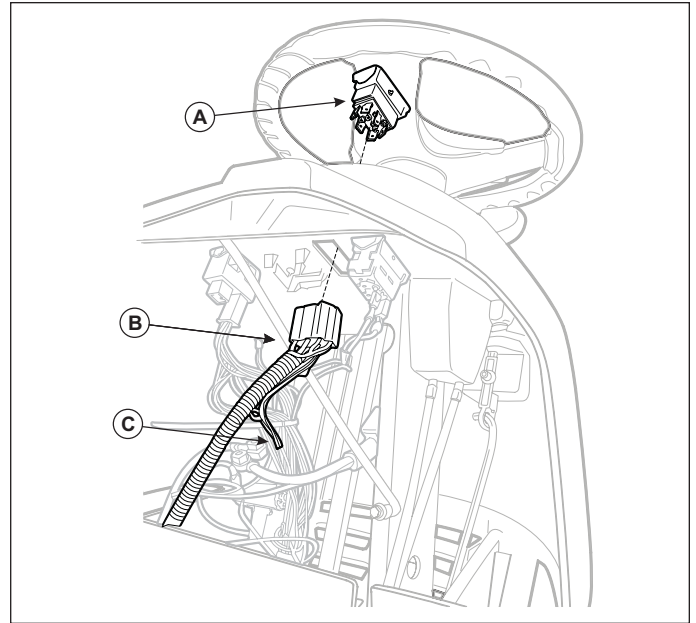

**Figure 19. Upper Wiring Harness**  
**A. Switch**  
**B. Female Receptacle**  
**C. Rotation Motor Power Leads**

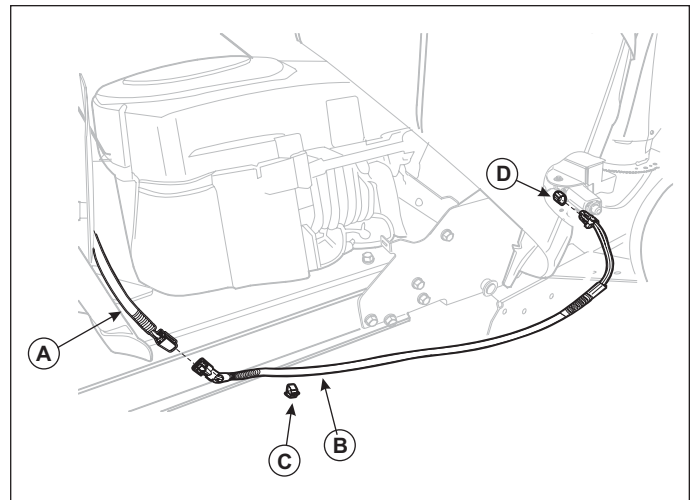

**Figure 20. Wiring Harness Connections**  
**A. Upper Wiring Harness**  
**B. Final Wiring Harness.**  
**C. Mounting Clip**  
**D. Chute Rotation Motor Connection**

# Removal



## Snow Thrower Removal

### **⚠ CAUTION**

Make sure to shut off the engine and locking the tractor brakes or block the rear wheels before beginning the snow thrower removal process.

1. Fully raise and support the snow thrower with wooden blocks.
2. Loosen the turn buckle (C, Figure 21) and then remove the lift assist spring, turn buckle and axle clamp.
3. Lower the snow thrower to the ground.
4. Move the belt tension lever to the RELEASED position (A, Figure 22).
5. Remove the snow thrower drive belt from the snow thrower pulley and PTO pulley.
6. Remove the two quick clips (D, Figure 23) securing the lift arm linkage and remove the lift arm linkage (C).

*NOTE: The Lift Arm assembly (A) will remain in place on the hitch assembly.*

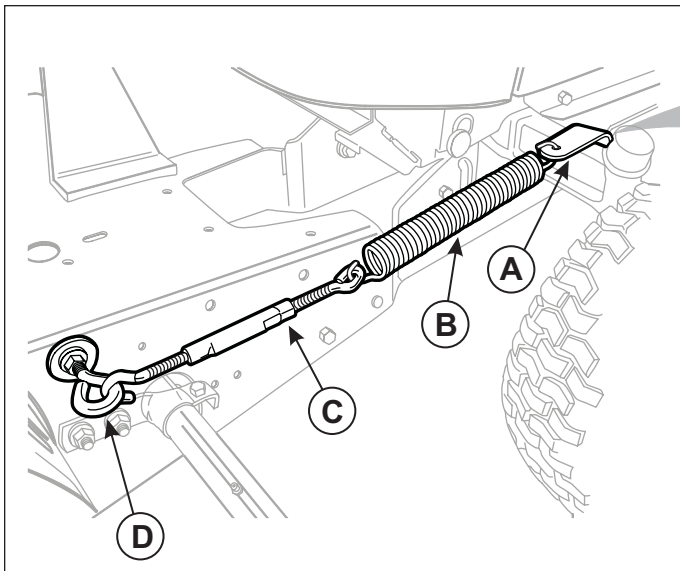

**Figure 21. Adjusting Belt Tension**

- A. Axle Clamp
- B. Spring
- C. Turnbuckle
- D. Eye-bolt

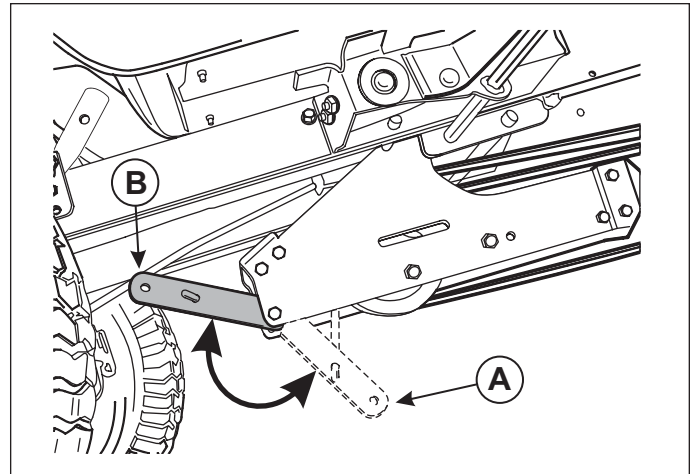

**Figure 22. Belt Tension Lever**

- A. Belt Tension Lever – Released Position
- B. Belt Tension Lever – Tension Position

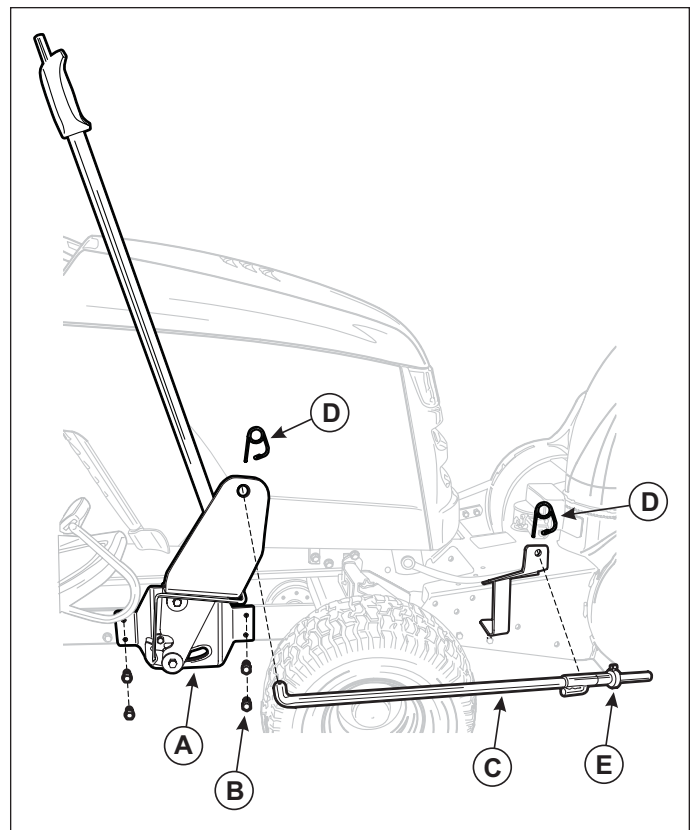

**Figure 23. Lift Arm Linkage**

- A. Lift Arm Assembly
- B. Mounting Bolts and Nuts
- C. Lift Arm Linkage
- D. Quick Clip
- E. Lifting Collar

7. Disconnect the final wiring harness (B, Figure 24).
8. Remove both quick clips (E, Figure 25) and snow thrower mounting pins (D).
9. Move the snow thrower assembly (A, Figure 25) out of the way.
10. Turn the front wheels fully to the left. Remove the latch pin quick clip (D, Figure 26) and slide the latch pin (A) to the left.

## CAUTION

Make sure to support the front of the hitch assembly as it will be loose when the latch pin has been removed.

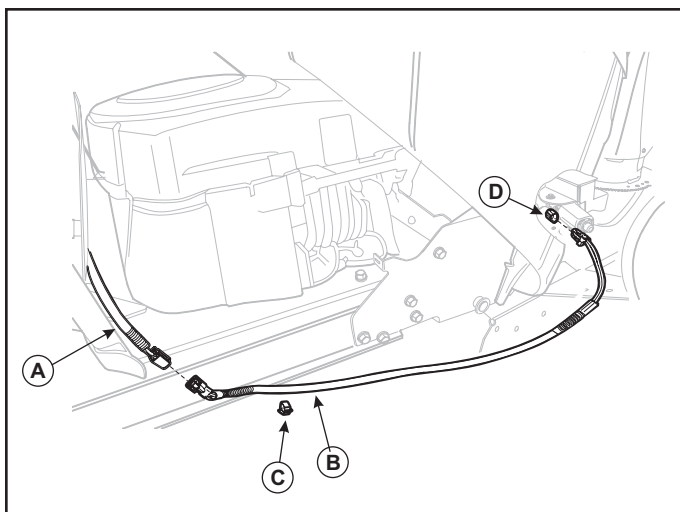

**Figure 24. Belt Routing**  
**A. Upper Wiring Harness**  
**B. Final Wiring Harness**  
**C. Mounting Clip**  
**D. Chute Rotation Motor Connector**

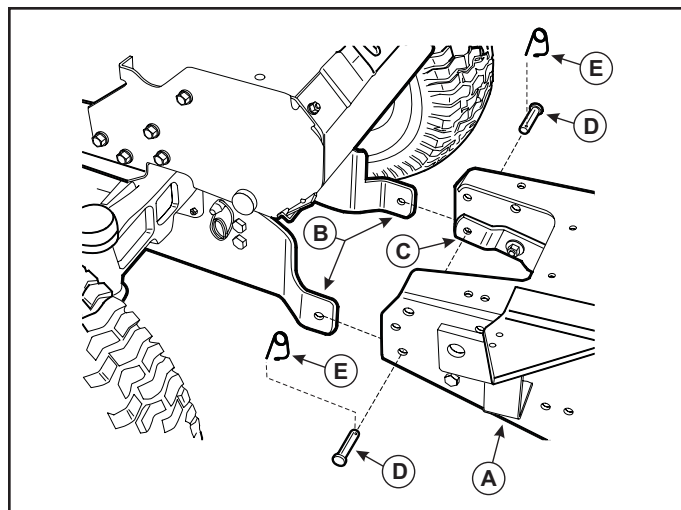

**Figure 25. Snow Thrower Installation**  
**A. Snow Thrower Assembly**  
**B. Hitch Mounting Arms**  
**C. Snow Thrower Mounting Tabs**  
**D. Mounting Pins**  
**E. Quick Clips**

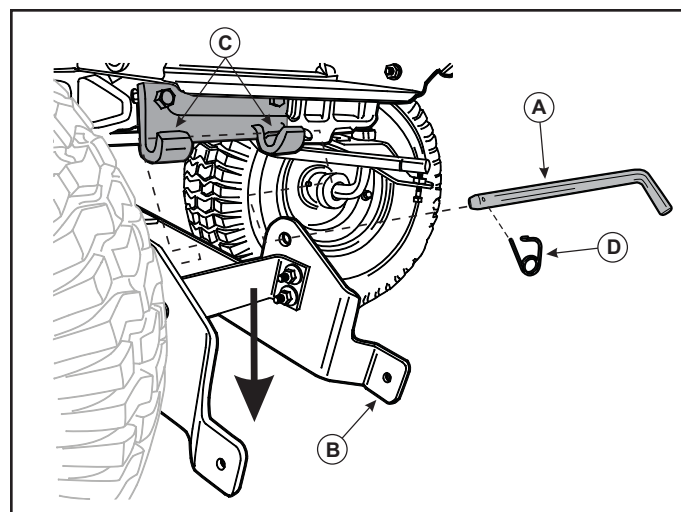

**Figure 26. Latch Pin Removal**  
**A. Hitch Latch Pin**  
**B. Hitch**  
**C. Frame Support Fingers**  
**D. Quick Clips**

## Removal

- Slide the hitch assembly (A, Figure 27) forwards until the hitch mounting arms (C) are free of the hitch support shaft (B).
- Slide the hitch to the right to move it from under the tractor.

*NOTE: The hitch support shaft (B) may be left in position and will not interfere with the operation of the lawn mower deck.*



### IMPORTANT NOTE

Inspect the snow thrower assembly, hitch assembly, snow thrower drive belt and all component parts for signs of wear or damage. Have these items repaired or serviced before reinstalling the snow thrower onto the tractor.

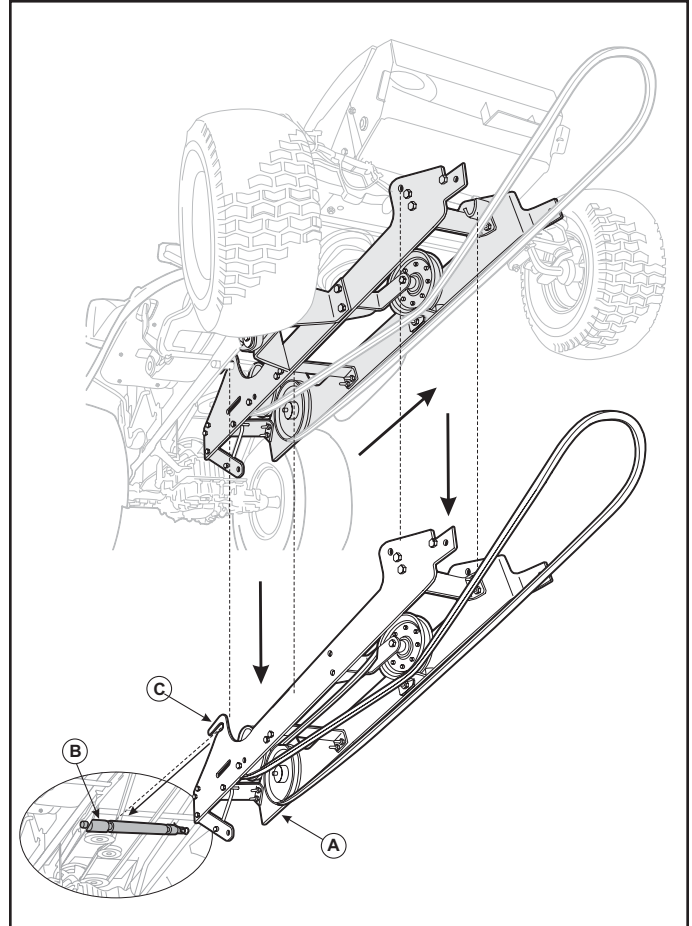

**Figure 27. Hitch Removal**

- A. Hitch Assembly**
- B. Hitch Support Shaft**
- C. Hitch Mounting Arms**











MANUFACTURING, INC.  
500 N Spring Street / PO Box 997  
Port Washington, WI 53074-0997

[www.SimplicityMfg.com](http://www.SimplicityMfg.com)



500 N Spring Street / PO Box 997  
Port Washington, WI 53074-0997

[www.MasseyLawn.com](http://www.MasseyLawn.com)



PRODUCTS  
535 Macon Street  
McDonough, GA 30253

[www.Snapper.com](http://www.Snapper.com)



500 N Spring Street / PO Box 997  
Port Washington, WI 53074-0997

[AGCOLawn.com](http://AGCOLawn.com)